



ARCADIA REPTILE



PRODUCT DATA SHEET

RARTZ

ThermalZoo Pro







GENERAL DESCRIPTION - a range of hybrid light and heat fittings. The unit can be fitted with combinations of Pro T5 and JD LED Bar lights. The unit can also be supplied with a variety of heat lamps. The fitting has been designed for commercial use in Zoos but can also be used in large domestic vivariums.

SPECIAL PRECAUTIONS

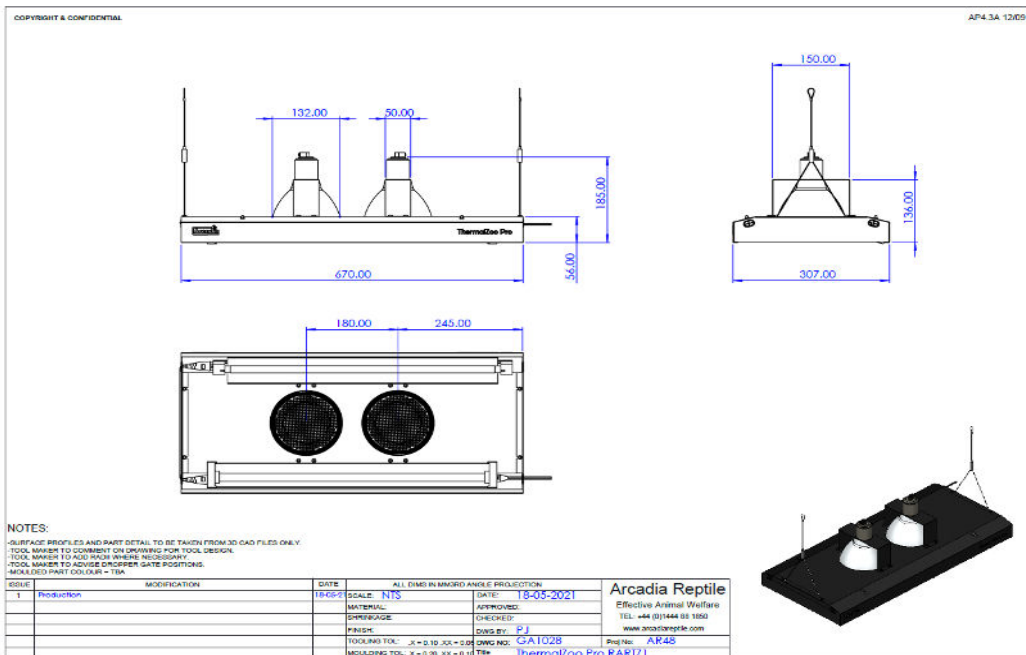
These tubes have a high light output, do not look directly at the tube when it is lit. Fluorescent tubes contain small amounts of mercury which would could be released if a tube is broken. The amount of mercury released would not be enough to pose a health risk to anyone immediately exposed but as a precautionary measure any room in which a tube breaks should be aired for 15 minutes. Do not use a vacuum cleaner or brush to remove debris as this risks further contamination. Wear disposable gloves. Carefully scoop up the larger bits of glass with a disposable piece of cardboard or similar. Use a piece of duct tape to pick up small pieces of glass and powder. Clean area with a paper towel. Seal all materials and cleaning equipment in a robust container and treat as hazardous waste. Thoroughly wash hands with soap and water. Dispose of in line with WEEE regulations.

LUMINAIRE DIMENSIONS







	ARCADIA REPTILE						
	PRODUCT DATA SHEET						
RARTZ	ThermalZoo Pro						 

MEASUREMENTS (based on supplied lamps)

	Nominal wattage	Power usage	Energy rating	Kelvin	UVA	UVB	UVI @ 300mm	UVI @ 600mm	
	W	kWh /1000h		K	%	%			
RARTZ1	See PDS for Pro T5 and JD LED Bar as well as individual heat lamps								
RARTZ2	See PDS for Pro T5 and JD LED Bar as well as individual heat lamps								

COLOUR SPECTRAL CHART wavelength nm

See PDS for Pro T5 and JD LED Bar as well as individual heat lamps

 MonkfieldReptile	ARCADIA REPTILE	
	PRODUCT DATA SHEET	
RARTZ	ThermalZoo Pro	 

COLOUR RENDER INDEX CHART

TEST EQUIPMENT

Power drawn	Everfine HAAS 1200 array spectroradiometer
Lumen output	Everfine HAAS 1200 array spectroradiometer
Colour temperature	Everfine HAAS 1200 array spectroradiometer
Lux	Iso-Tech Light Meter model 1335
PAR	Apogee PAR meter model MQ-500
UVA	Solarmeter UV Index model 6.5
UVB	Solarmeter UV Index model 6.5
UVC	Solarmeter UVC meter model 8.0
Energy eff. Calcs	EU reg 874/2012 Energy labelling of electrical lamps and luminaires

ADDITIONAL PARTS

HARMONISED STANDARDS

LVD	RoHS
EN60598-1:2015	EN50581:2012
EN62471:2008	
EN62493:2010	
EMC	
EN55015:2013	
EN61547:2009	
EN61000-3-2:2014	
EN61000-3-3:2013	